

UETDRELO06

Work Safely in the Vicinity of Live Electrical Apparatus as a Non-Electrical Worker

Learner Guide Instructions

Who is this document for?

The learner.

What is in this document?

- Course training content (this matches the PowerPoint Presentation).
- Review questions.

What do you need to do before you use it for the first time?

1. Rebrand the document.
2. Review the document as part of your validation process.

See the 'Read Me First' document for a complete set of instructions on how to use these resources.



LEARNER GUIDE

UETDREL006 Work Safely in the Vicinity of Live Electrical Apparatus as a Non-Electrical Worker

Learner Name:	
Learner ID:	
Learner Contact Number:	
Learner Email Address:	
Date Training Commenced:	

This Book Contains:

- Course Information.
- Review Questions.

Table of Contents

1.1 Introduction	5
1.1.1 Working Around Electrical Apparatus	5
1.1.2 What is a Safety Observer?	6
1.1.2.1 Safety Observer – General Requirements	7
Review Questions	7
1.2 What is Electricity?	8
1.2.1 Voltage	8
1.2.1.1 Why Measuring Voltage is Useful	10
1.2.1.2 Amperes	10
1.2.1.3 Watts	11
1.2.2 Electrical Resistance	11
1.2.2.1 Ohm's Law	12
1.2.2.2 Analysing Simple Circuits with Ohm's Law	12
1.2.3 Current	14
1.2.3.1 Three Effects of Electric Current: Heating, Magnetism and Chemical Effects	14
1.2.3.2 Three Phase and Single Phase Electrical Systems	14
1.2.4 Circuits	16
1.2.5 Arc Fault	17
Review Questions	18
1.3 Legislative Requirements and Guidelines	19
1.3.1 Code of Practice on Electrical Safety for Work on or Near High Voltage Electrical Apparatus	19
1.3.2 Duty of Care	20
Review Questions	20
1.4 Confirm Work Instructions	21
1.4.1 Organise Materials for Work	21
Review Questions	22
1.5 Select and Check Plant, Tools and Equipment	22
1.5.1 Personal Protection Equipment	23
1.5.1.1 Protective Clothing	23
1.5.1.2 Helmets	24
1.5.1.3 Harnesses	25
1.5.1.4 Low Voltage Insulating Gloves	25
1.5.1.5 Eye Protection	26
1.5.1.6 Low Voltage Detectors	26
1.5.1.7 Low Voltage Indicating Devices (Volt Sticks)	26
Review Questions	27
1.6 Electricity Infrastructure Assets	27
1.6.1 Electricity Supply	28
1.6.2 Generation	28
1.6.3 Transmission	28
1.6.4 Distribution	29
1.6.4.1 Underground Power Lines	29
1.6.4.2 Stobie Poles and Transmission Towers	30
1.6.4.3 Power Line Insulators	31
1.6.5 Rail Transmission, Distribution and Traction Systems	32
1.6.6 Earthing	33
Review Questions	33
1.7 Work Permits	34
1.7.1 Applying for a Permit	39
1.7.2 Issuing a Work Permit	39
Review Questions	40
1.8 Communication Methods and Equipment	41
1.8.1 Radio	41
1.8.2 Mobile Phone	42
Review Questions	42

2.1 Approach Distance When Working Near Overhead Power Lines	43
2.1.1 How Close Can I Go to Overhead Power Lines	44
2.1.2 Accredited Person Zone	45
2.1.2.1 Approach Distances for Work Performed by an Accredited Person with a Safety Observer	46
2.1.3 Work Inside the No Go Zone – Approval of The Network Operator	46
2.1.4 Approach Distances for Vehicles	47
2.1.5 Work Near Overhead Power Lines – General Risk Management Principles	48
Review Questions	48
2.2 The Basics of Working Safely Near Power Lines	49
2.2.1 What is the Risk?.....	49
2.2.2 How Can you Avoid These Incidents?	49
2.3 Risk Management Process	50
2.3.1 Consulting with Other Workers About Hazards and Risks.....	50
2.3.2 Visual Indicators to Identify Overhead Power Lines.....	50
2.3.3 Weather Factors.....	51
2.3.4 Assess Risks.....	52
2.3.5 Control Hazards to Reduce Risks.....	53
2.3.5.1 Isolating the Power Supply	54
Review Questions	54
2.4 Mobile Plant and Cranes	55
2.4.1 Identify Hazards and Assess Risks.....	55
2.4.2 Implement Control Measures	56
2.4.2.1 Elimination.....	57
2.4.2.2 Isolation	57
2.4.2.3 Administrative Controls	58
2.4.3 Maintain Communication with Plant Operators	58
Review Questions	59
2.5 Working at Heights	60
2.5.1 Safely Carry Out the Work.....	60
2.5.2 Working on a Portable Ladder	61
Review Questions	61
2.6 Scaffolds	62
2.6.1 Identify Hazards and Assess Risks.....	62
2.6.2 Implement Control Measures	63
Review Questions	63
2.7 Tree and Vegetation Management	64
2.7.1 Identify Hazards and Assess Risks.....	64
2.7.2 Implement Control Measures	65
2.7.3 Carry Out Work	65
Review Questions	66
2.8 Low Voltage Overhead	66
2.8.1 Identify Hazards and Assess Risks.....	67
2.8.2 Implement Control Measures	67
2.9 Contact with Power Lines and Other Electrical Emergencies	68
2.9.1 Emergency Response to an Electric Shock	68
Review Questions	69
3.1 Complete Work and Documentation	70
3.1.1 Close or Handover Work Permits.....	70
3.1.2 Complete Required Documentation	71
Review Questions	71

1.1 Introduction

This course is based on the unit of competency **UETDREL006 Work Safely in the Vicinity of Live Electrical Apparatus** as a non-electrical worker.

You will learn about:

- ◆ Preparing to work safely in the vicinity of live electrical apparatus.
- ◆ Principles of Electricity.
- ◆ Legislation, regulations and guidelines to be followed.
- ◆ Hazard controls.
- ◆ Work permits.
- ◆ Ways to work safely in different situations with different equipment around live electrical apparatus.
- ◆ Completing workplace documentation.

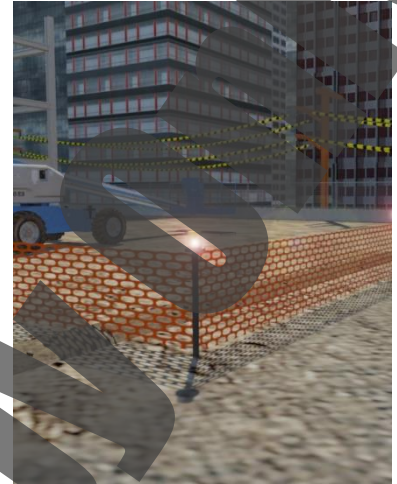

1.1.1 Working Around Electrical Apparatus

The danger of working around electricity cannot be understated. Electricity can pose a serious risk of death, shock or other injury caused directly or indirectly by electricity.

The main hazards associated with these risks are:



- ◆ Contact with exposed live parts causing electric shock and burns (for example exposed leads or other electrical equipment coming into contact with metal surfaces such as metal flooring or roofs).
- ◆ Faults which could cause fires.
- ◆ Fire or explosion where electricity could be the source of ignition in a potentially flammable or explosive atmosphere (for example in a spray paint booth).

The risk of injury from electricity is strongly linked to where and how it is used. The risks are greatest in harsh conditions, for example:

- ◆ Outdoors or in wet surroundings - equipment may become wet and may be at greater risk of damage.
- ◆ In cramped spaces with earthed metalwork, such as inside a tank or bin - it may be difficult to avoid electrical shock if an electrical fault develops.



Some items of equipment can also involve greater risk than others. Portable electrical equipment is particularly liable to damage, including to plugs and sockets, electrical connections, and to the cable itself. Extension leads, particularly those connected to equipment which is frequently moved, can suffer from similar problems.

Source: *ELECTRICAL RISKS AT THE WORKPLACE FACT SHEET (2012), Safe Work Australia*

According to Safe Work Australia's statistics, fatalities on the job relating to contact with electricity are listed below:

Year	Contact with Electricity
2003	13
2004	16
2005	13
2006	18
2007	13
2008	9
2009	13
2010	10
2011	10
2012	6
2013	8
2014	5
2015	8
2016	7
2017	4
2018	4
2019	8
2020	7
2021	7

1.1.2 What is a Safety Observer?

A safety observer, also known as an electrical spotter, is a trained individual responsible for monitoring the work environment to identify potential hazards and to help prevent accidents and injuries.

In the context of electrical work, a safety observer is responsible for ensuring the safety of workers, plant, and equipment in the vicinity of electrical apparatus and power lines.

Their role is to identify and manage potential electrical hazards, communicate any concerns or risks to workers and supervisors, and maintain a safe work environment.

The safety observer plays a critical role in preventing accidents and injuries in hazardous work environments.



1.1.2.1 Safety Observer – General Requirements

When workers, plant, or equipment are working in the vicinity of electrical apparatus and power lines, there are specific requirements that a safety observer must follow to ensure that everyone in the area remains safe. These requirements include:

1. **Qualifications:** The safety observer should be appropriately qualified and trained in the safe working practices around electrical apparatus and power lines. They should have a good understanding of the electrical hazards and risks associated with working in the area.
2. **Communication:** The safety observer should maintain clear and effective communication with workers in the area, including those operating equipment, to ensure that everyone is aware of any hazards or changes in the work environment.
3. **Observation:** The safety observer should be positioned in a location where they can observe and continually monitor the work area to identify any potential hazards or dangerous situations. They should remain vigilant and alert to any signs of electrical danger, including arcing, sparks, or smoke.
4. **Hazard identification:** The safety observer should be able to identify potential electrical hazards, such as exposed wires, overloaded circuits, and faulty electrical equipment that could cause electrocution, electrical fires, or other dangerous situations.
5. **Control measures:** The safety observer should ensure that appropriate control measures are in place to manage the risks associated with working in the area. This may include establishing safe work zones, using appropriate signage, and implementing other protective measures, such as insulating barriers.
6. **Emergency procedures:** The safety observer should be familiar with emergency procedures, including first aid, CPR, and evacuation procedures, in case of an electrical emergency.
7. **Record keeping:** The safety observer may be required to maintain records of safety observations, incidents, and other relevant information.



Overall, the safety observer plays a critical role in ensuring the safety of workers, plant, and equipment in the vicinity of electrical apparatus and power lines. They must remain alert, vigilant, and trained to identify and manage potential electrical hazards to prevent accidents and injuries.

Review Questions

1.	What is a safety observer?	<input type="checkbox"/>

1.2 What is Electricity?

Electricity is the flow of charged particles, usually electrons, through a conductive material such as a wire or a circuit.

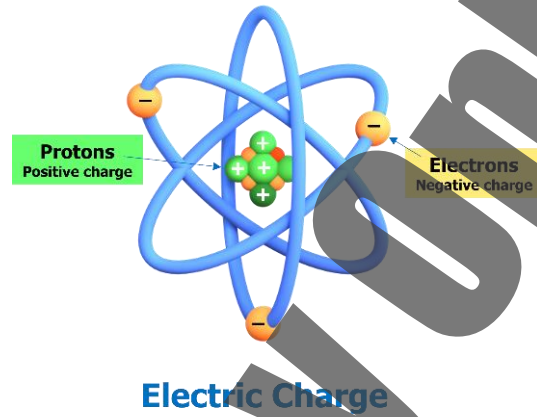
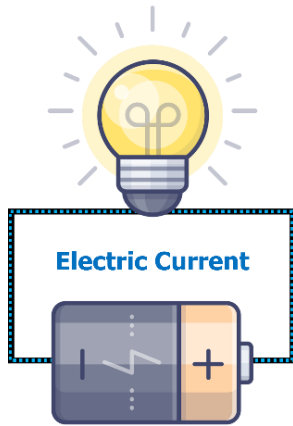

Electricity can be generated by various means, including chemical reactions, nuclear reactions, and the movement of magnets through a coil of wire. It can be measured in units such as volts, amperes, and watts, and can be either direct current (DC), flowing in a single direction, or alternating current (AC), changing direction periodically.

1.2.1 Voltage

Voltage is the measure of the electric potential difference between two points in an electrical circuit, representing the amount of electrical energy that would be required to move a unit of electric charge from one point to another. It is often described as the "pressure" or "push" that causes electric current to flow in a circuit. Voltage is typically measured in volts (V) and is denoted by the symbol "V".

When a circuit is closed, meaning that the wires or other components form a complete loop, electrons can flow through the circuit from the negative terminal of the power source to the positive terminal. The voltage provided by the power source pushes these electrons through the circuit, creating a flow of electrical current. This would cause the bulb in this example to glow as the current moves through it.

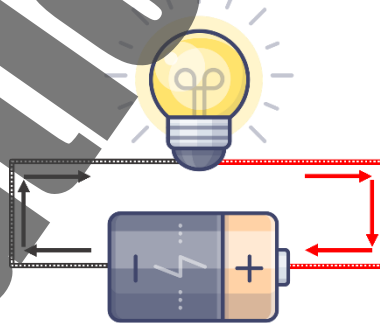

The main difference between alternating current (AC) and direct current (DC) is the direction of the flow of electric charge.

In a DC circuit, electric charge flows in only one direction. This is because the voltage or potential difference between the two terminals of the power source remains constant in magnitude and polarity. This means that the current flowing in the circuit is always in the same direction, and does not change with time.

In an AC circuit, however, the direction of the flow of electric charge alternates periodically. This is because the voltage or potential difference between the two terminals of the power source changes polarity and magnitude over time, resulting in a current that changes direction periodically. AC power is typically produced by generators that use rotating magnetic fields to produce a fluctuating voltage.

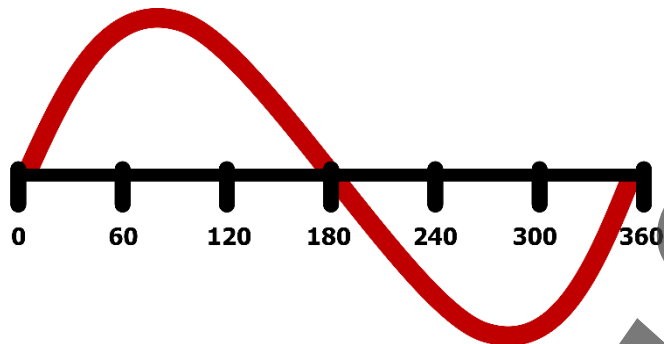

Another key difference between AC and DC is the way in which they are used. DC is commonly used in electronic devices such as batteries, as well as in certain types of motors and power supplies. AC, on the other hand, is the type of power that is typically used in homes and buildings to power appliances, lighting, and other electrical devices.

Generators are devices that convert mechanical energy into electrical energy through the use of electromagnetic induction. They work by using a magnetic field to induce a flow of electrons in a conductor, creating an electrical current.

In a typical generator, there are two main components: a stationary part called the stator, and a rotating part called the rotor. The stator consists of a set of wire coils that are arranged in a circular pattern around the rotor, and the rotor consists of a shaft with magnets attached to it. When the rotor is rotated, the magnets move past the coils in the stator, which induces an electrical current to flow through the wire coils.

ELECTRIC GENERATOR

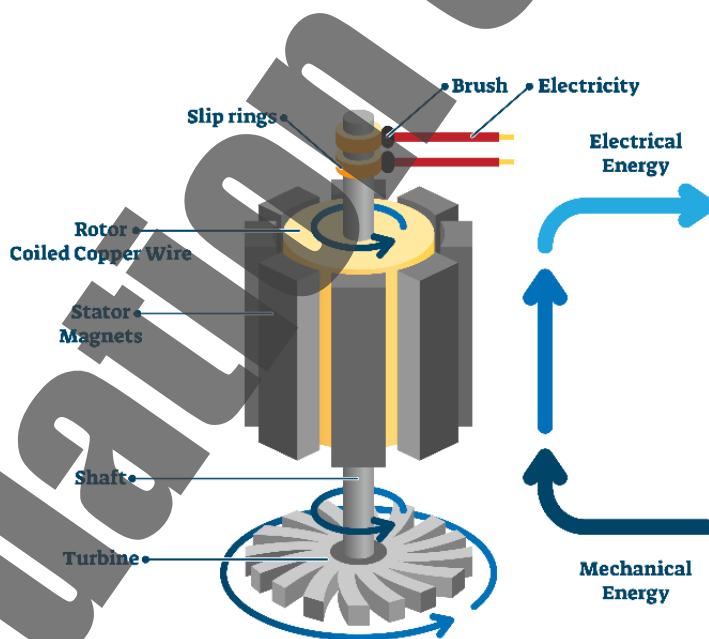

When the rotor is rotated, it creates a magnetic field that interacts with the magnetic field of the stator. The interaction between these two fields causes the wire coils in the stator to become energized, which generates an electrical current. The current produced by the generator is typically an alternating current (AC), which means that the direction of the current alternates periodically.



In a hydroelectric power plant, water is used to turn a turbine, which rotates the rotor of the generator. The flowing water drives the turbine blades, which are connected to the rotor shaft. As the rotor spins, the magnets attached to it create a magnetic field that interacts with the wire coils in the stator, producing an electrical current. The electrical current is then sent through a transformer to increase its voltage and transmitted through power lines to homes and businesses.

In a thermal power plant, steam is produced by heating water with fossil fuels (gas, oil, coal) or nuclear power. The steam drives a turbine, which rotates the rotor of the generator in the same way as in a hydroelectric power plant.

1.2.1.1 Why Measuring Voltage is Useful

Measuring voltage in an electrical circuit is useful for several reasons:

1. **Circuit troubleshooting:** Voltage measurements can help identify problems in an electrical circuit. For example, if a voltage measurement across a component is significantly lower than expected, it may indicate that the component is faulty or that there is a problem with the circuit's power supply.
2. **Safety:** Measuring voltage is essential for ensuring electrical safety. High voltages can pose significant risks to workers and equipment and measuring voltage can help identify potentially dangerous situations before they lead to accidents or injuries.
3. **Component selection:** The voltage rating of electrical components, such as capacitors and resistors, must be matched to the circuit's voltage to ensure proper operation. Measuring voltage can help identify the correct components for a given circuit.
4. **Efficiency:** Measuring voltage can help optimise the efficiency of electrical circuits. By measuring the voltage drop across a resistor or other component, it is possible to calculate the amount of power being dissipated, which can help identify opportunities for reducing power consumption and improving energy efficiency.

Overall, measuring voltage is essential for ensuring the proper operation, safety, and efficiency of electrical circuits. It is a fundamental tool for electrical engineers, technicians, and electricians.



1.2.1.2 Amperes

Amperes, often abbreviated as "amps," is the unit of measurement for electric current and is defined as the amount of electric charge that flows through a conductor in one second when a potential difference of one volt is applied across the conductor.



1.2.1.3 Watts

Watts are used to express the power of electrical devices, such as light bulbs, motors, and heaters. In an electrical circuit, the wattage is equal to the voltage multiplied by the current, or $W = V \times A$, where W is power in watts, V is voltage in volts, and A is current in amperes.



1.2.2 Electrical Resistance

Electrical resistance is the measure of how much a material or component resists the flow of electric current through it. It is measured in ohms (symbol Ω) and is determined by the properties of the material or component, such as its composition, size, and shape.

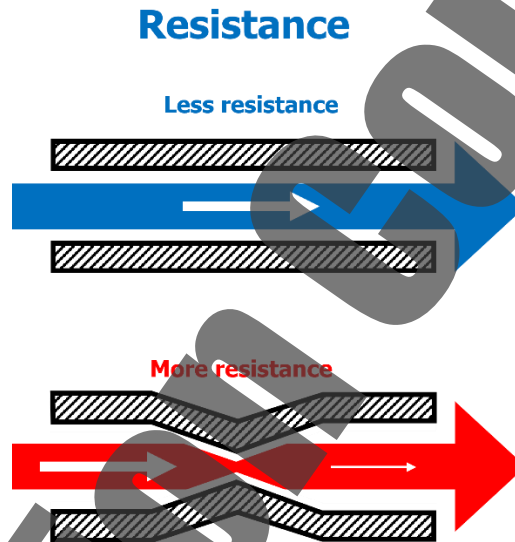

The resistance of a material is directly proportional to its length and inversely proportional to its cross-sectional area. This means that a longer and narrower wire will have higher resistance than a shorter and wider wire made of the same material.

Electrical resistance is important because it determines how much current can flow through a material or component for a given voltage. Materials with high resistance, such as insulators, restrict the flow of current, while materials with low resistance, such as metals, allow current to flow more easily.

1.2.2.1 Ohm's Law

Ohm's law describes the relationship between voltage, current, and resistance in an electrical circuit. It states that the current flowing through a conductor between two points is directly proportional to the voltage across the two points, and inversely proportional to the resistance between them. Mathematically, Ohm's law can be expressed as:

$$E = IR$$

Where E is the voltage in volts (V), I is the current in amperes (A), and R is the resistance in ohms (Ω). This means that if the voltage is doubled, the current will also double, provided the resistance remains constant. Alternatively, if the resistance is doubled, the current will be halved, provided the voltage remains constant.

1.2.2.2 Analysing Simple Circuits with Ohm's Law

Here is an example of how Ohm's Law is applied to a circuit.

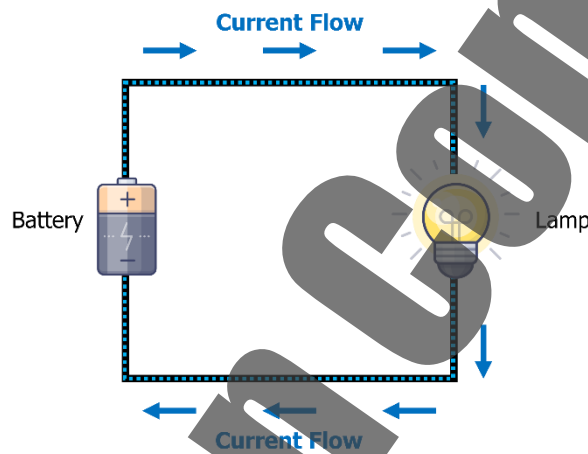

In the above circuit, there is only one source of voltage (the battery, on the left) and only one source of resistance to current (the lamp, on the right). This makes it very easy to apply Ohm's Law. If we know the values of any two of the three quantities (voltage, current, and resistance) in this circuit, we can use Ohm's Law to determine the third.

In this first example, we will calculate the amount of current (I) in a circuit, given values of voltage (E) and resistance (R):

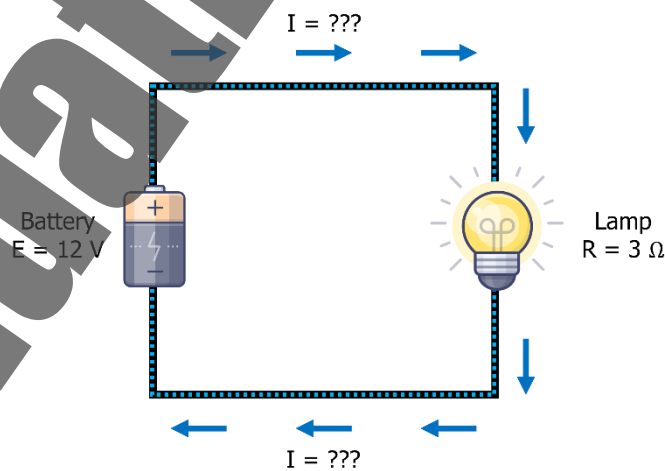

What is the amount of current (I) in this circuit?

$$I = \frac{E}{R} = \frac{12V}{3\Omega} = 4A$$

In this second example, we will calculate the amount of resistance (R) in a circuit, given values of voltage (E) and current (I):

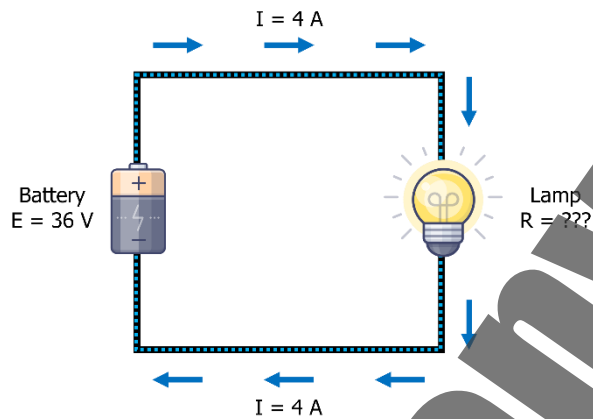

What is the amount of resistance (R) offered by the lamp?

$$R = \frac{E}{I} = \frac{36V}{4A} = 9\Omega$$

In the last example, we will calculate the amount of voltage supplied by a battery, given values of current (I) and resistance (R):

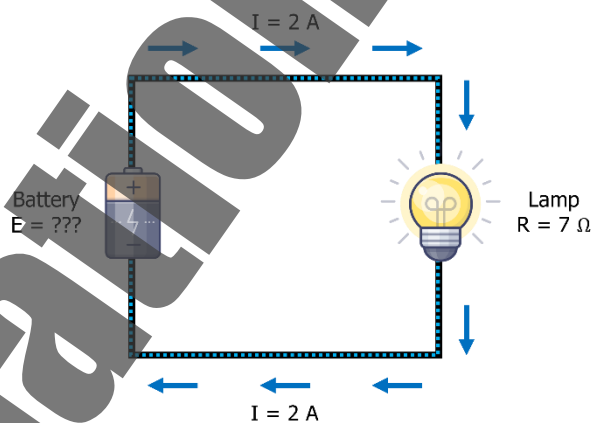

What is the amount of voltage provided by the battery?

$$E = IR = (2A)(7\Omega) = 14V$$

1.2.3 Current

Electrical current is the flow of electric charge in a circuit. It is the rate at which electric charges (usually electrons) flow through a material or a conductor. The unit of electric current is the ampere (A).

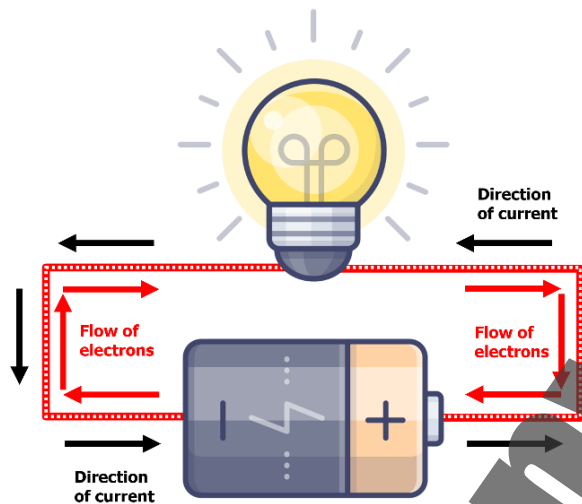

1.2.3.1 Three Effects of Electric Current: Heating, Magnetism and Chemical Effects

An electric current has three main effects:

- ◆ **Heating effect** – cooking, light, electrical appliances.
- ◆ **Magnetic effect** (Magnetism) – circuit breakers, bells, door locks, telephone ear piece.
- ◆ **Chemical effect** – electroplating, extracting metals from ore, purifying metals.



1.2.3.2 Three Phase and Single Phase Electrical Systems

Electricity is either connected at 230 or 240 volts (single-phase, which accounts for the majority of domestic situations), or 400 and 415 Volts (three-phase). The latter is better suited to providing for powerful appliances and fixed plant, and is more commonly used by industrial and larger commercial users.

1-phase and 3-phase motor connections

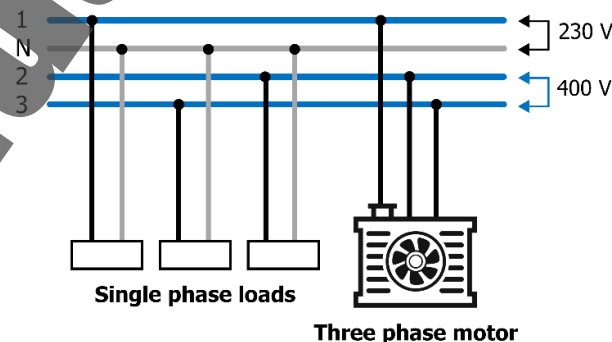

A three-phase system is a type of electrical power transmission that uses three alternating current (AC) voltages that are out of phase with each other by 120 degrees. This system is widely used in large-scale power distribution systems, industrial machinery, and motor control applications.

In a three-phase system, three separate conductors carry three different AC voltages, each with the same magnitude and frequency but with a phase difference of 120 degrees between them. These three-phase AC voltages are typically generated by a three-phase generator or alternator.

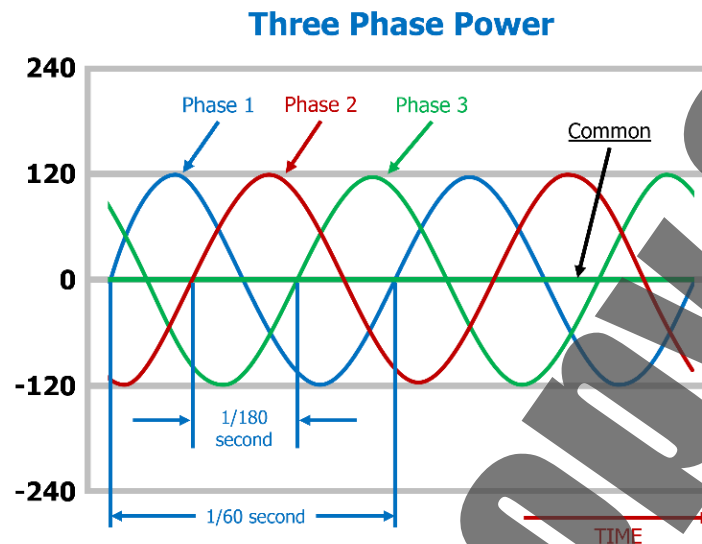

When these three-phase voltages are applied to a balanced load (i.e., a load that is symmetrical and evenly distributed among the three phases), the load receives a constant and smooth supply of power. The three-phase system provides several advantages over a single-phase system, including higher power transfer efficiency, reduced voltage drop, and the ability to operate larger motors.

A single-phase system is a type of electrical power distribution system that uses a single alternating current (AC) voltage. This system is commonly used for residential and small commercial applications where the power demand is relatively low.

In a single-phase system, a single AC voltage is applied to the load, which typically consists of resistive loads such as lighting, heating, and small motors. The voltage waveform is a sine wave that alternates in polarity at a fixed frequency, typically 50 or 60 Hz.

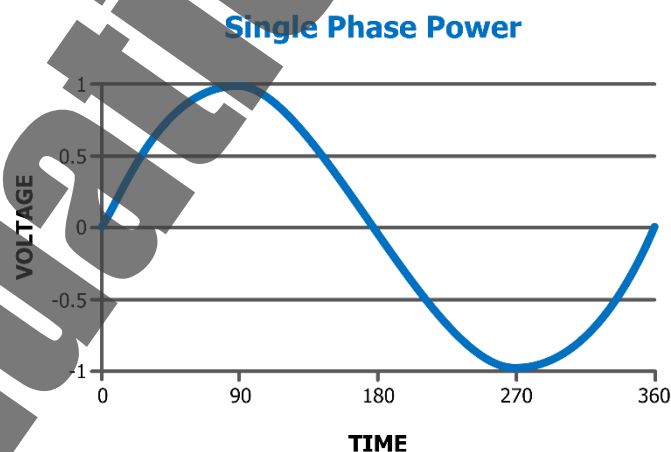

1.2.4 Circuits

An electrical circuit is a path or loop through which electric current can flow. It consists of various electrical components such as wires, resistors, capacitors, inductors, diodes, transistors, and other electronic components that are connected together to perform a specific task.

When a voltage is applied to an electrical circuit, the electric charges (usually electrons) in the circuit start to flow through the path or loop, from the negative terminal of the voltage source, through the various components in the circuit, and back to the positive terminal of the voltage source.

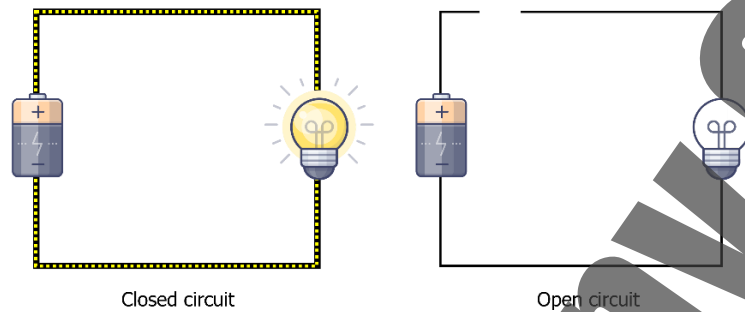

The flow of electric charges through the circuit is known as electric current, which is typically measured in amperes (A). The speed of the electric current is determined by the voltage and the resistance of the circuit, according to Ohm's law.

The components in an electrical circuit can be arranged in various configurations, such as series, parallel, or a combination of both, to achieve different results. For example, a series circuit has all its components connected end-to-end, so the same current flows through each component, whereas a parallel circuit has its components connected across each other, so the voltage is the same across each component.

When a switch in a circuit is open, it means that the switch is in the "off" position, and the circuit is broken, which prevents current from flowing through the circuit. In this state, the circuit is considered to be incomplete or open. If there is no other path for the current to flow, the load in the circuit, such as a light bulb or a motor, will not receive any power and will not operate.

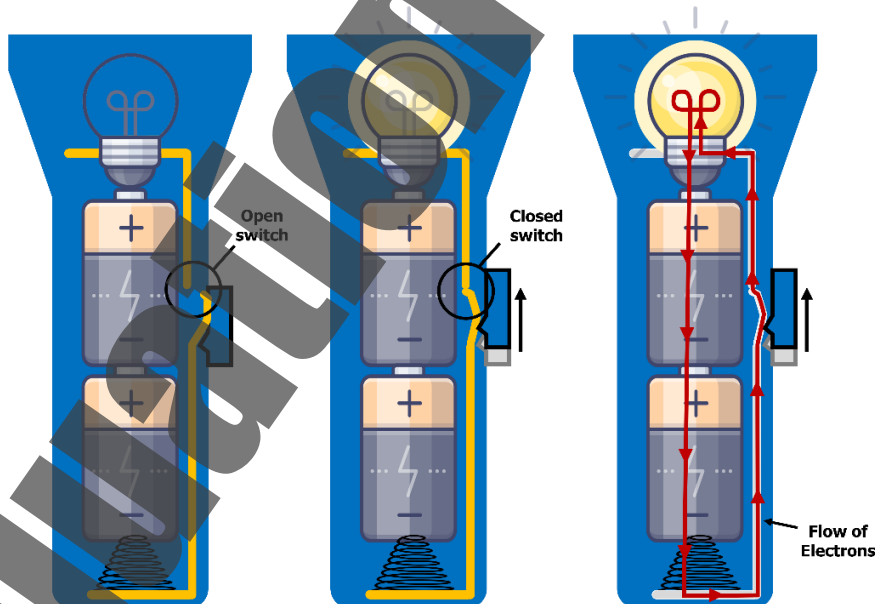

When the switch is open, the voltage across the switch is equal to the source voltage, and there is no current flowing through the switch. However, there may be some residual voltage across the switch due to the capacitance or inductance of the circuit.

To restore the circuit to the "on" state, the switch must be closed or turned "on" to complete the circuit and allow current to flow. When the switch is closed, the voltage across the switch drops to zero, and the current flows through the circuit and the load, allowing it to operate.